

- NOTES; UNLESS OTHERWISE SPECIFIED:-**
1. ALL OUTPUTS OF C3, 2519 (PINS 7 THRU 12), ARE PROVIDED WITH "PULL-DOWN" RESISTORS, 7500 OHMS EACH, TO -12V.
 2. INTERCONNECTIONS BETWEEN SCHEMATIC SECTIONS ARE INDICATED BY [] AREAS.
 3. ALL RESISTORS ARE IN OHMS, 1/4W, 5%.
 4. ALL CAPACITOR VALUES ARE IN MICROFARADS.
 5. ALL DIODES ARE TYPE 1N914.
 6. ALL GATES ARE 74' SERIES DEVICES.
- (See additional notes, sheet 2/3)

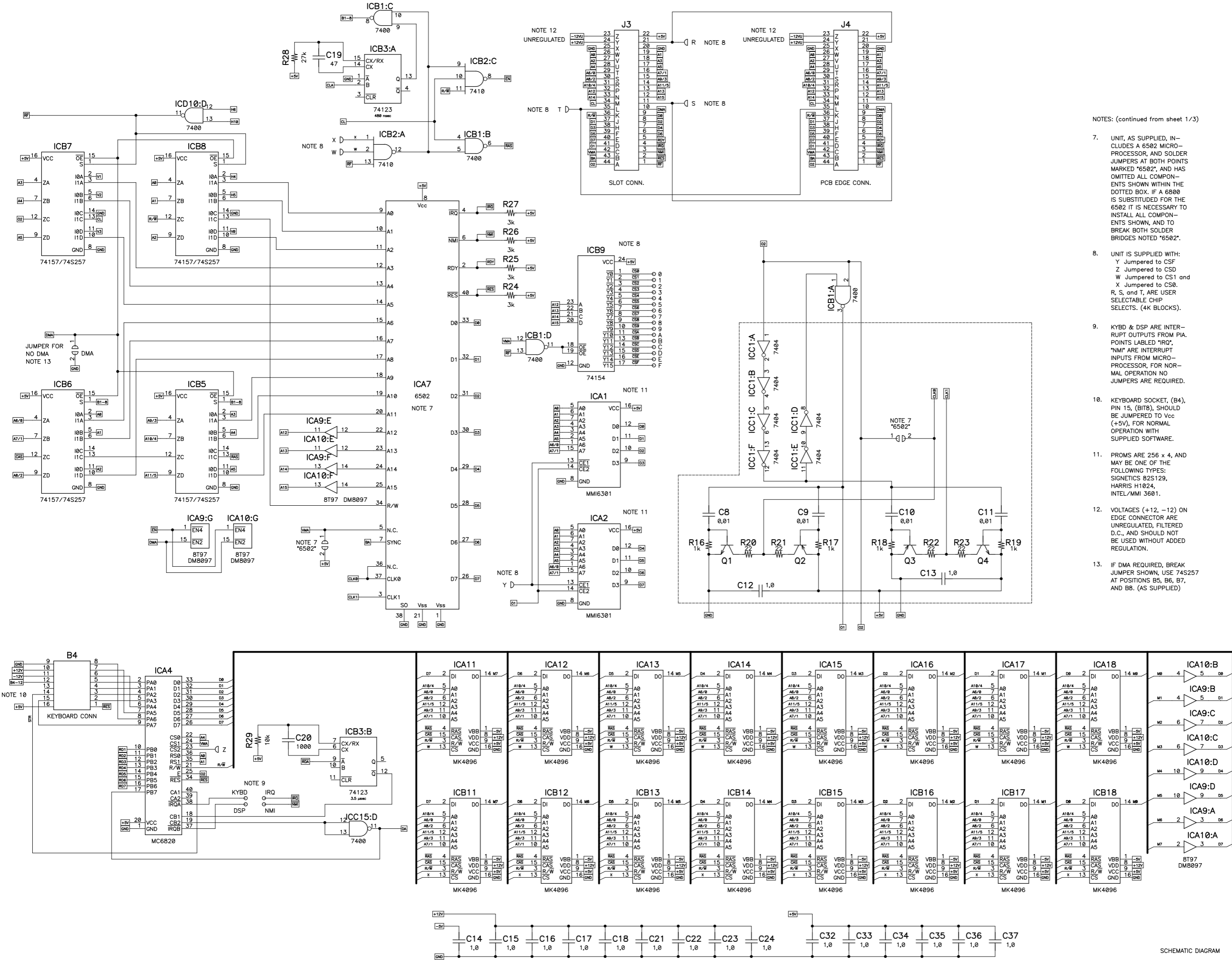

NOTES: (continued from sheet 1/3)

- UNIT, AS SUPPLIED, INCLUDES A 6502 MICRO-PROCESSOR, AND SOLDER JUMPERS AT BOTH POINTS MARKED "6502", AND HAS OMITTED ALL COMPONENTS SHOWN WITHIN THE DOTTED BOX. IF A 6800 IS SUBSTITUTED FOR THE 6502 IT IS NECESSARY TO INSTALL ALL COMPONENTS SHOWN, AND TO BREAK BOTH SOLDER BRIDGES NOTED "6502".
- UNIT IS SUPPLIED WITH:
Y Jumped to CSF
Z Jumped to CS1
W Jumped to CS1 and X Jumped to CS0.
R, S, and T, ARE USER SELECTABLE CHIP SELECTS. (4K BLOCKS).
- KYBD & DSP ARE INTERRUPT OUTPUTS FROM PIA. POINTS LABELED "IRQ", "NMI" ARE INTERRUPT INPUTS FROM MICRO-PROCESSOR, FOR NORMAL OPERATION NO JUMPERS ARE REQUIRED.
- KEYBOARD SOCKET, (B4), PIN 15, (BITB), SHOULD BE JUMPED TO Vcc (+5V), FOR NORMAL OPERATION WITH SUPPLIED SOFTWARE.
- PROMS ARE 256 x 4, AND MAY BE ONE OF THE FOLLOWING TYPES: SIGNETICS 82S129, HARRIS H1024, INTEL/MMI 3601.
- VOLTAGES (+12, -12) ON EDGE CONNECTOR ARE UNREGULATED, FILTERED D.C., AND SHOULD NOT BE USED WITHOUT ADDED REGULATION.
- IF DMA REQUIRED, BREAK JUMPER SHOWN, USE 74S257 AT POSITIONS B5, B6, B7, AND B8. (AS SUPPLIED)

105-125 VAC 60 Hz
POWER SOURCE

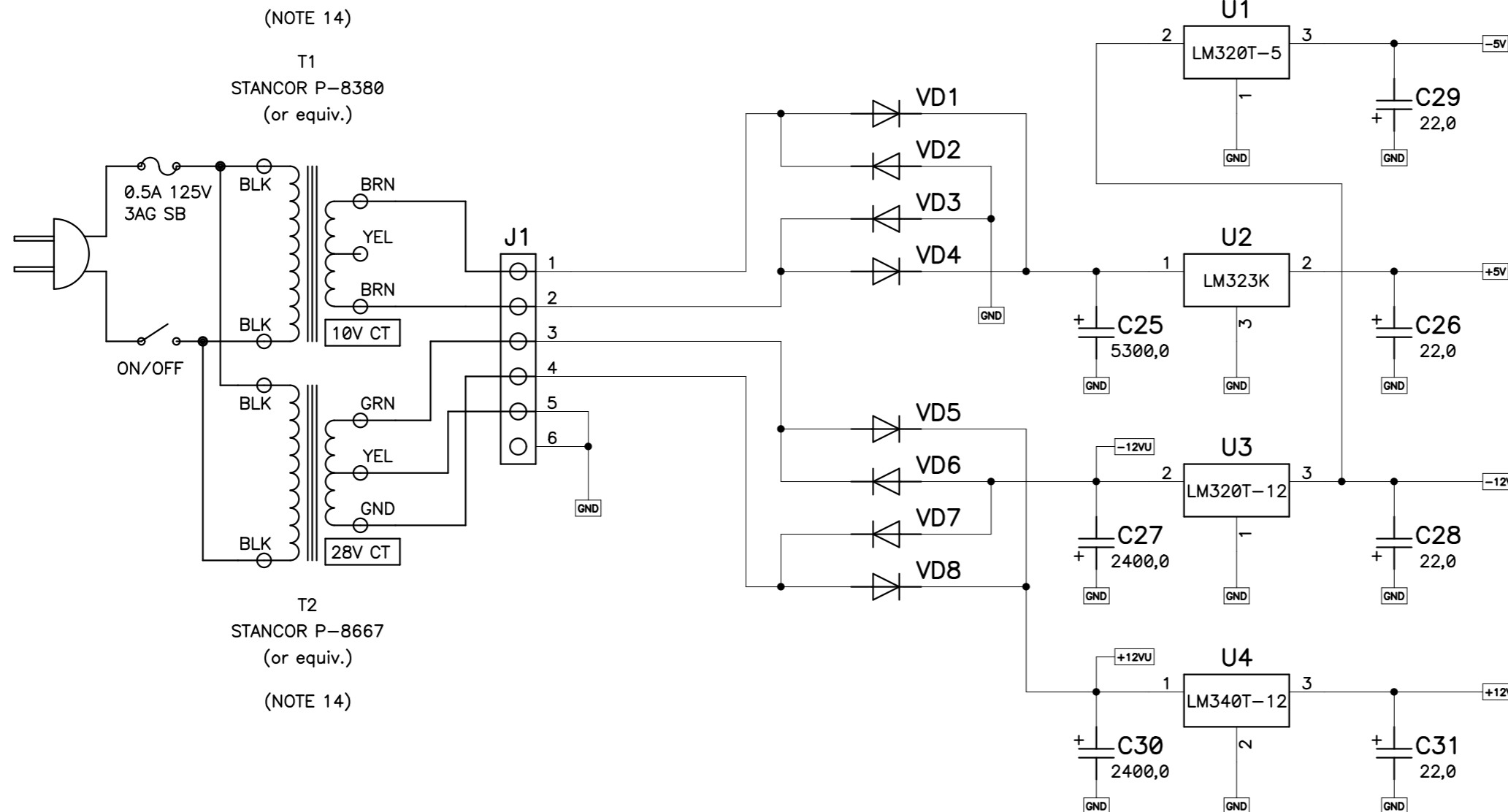

Power Table				
Ref Des	Device(Type)	Package	GND	+5V
ICA9	8T97	N016	8	16
ICA10	8T97	N016	8	16
ICB1	7400	N014	7	14
ICB2	7410	N014	7	14
ICB3	74123	N016	8	16
ICC1	7404	N014	7	14
ICC5	7427	N014	7	14
ICC6	7410	N014	7	14
ICC8	7450	N014	7	14
ICC9	7432	N014	7	14
ICC10	7402	N014	7	14
ICC12	7408	N014	7	14
ICC15	7400	N014	7	14
ICD10	7400	N014	7	14
ICD12	7404	N014	7	14
U2	LM323K	1-03	4	

NOTES: (continued from sheet 2/3)

14. T1 EQUIVALENT TRANSFORMER SHALL BE 8 TO 10 VOLT SECONDARY, WITH 3 AMP MINIMUM CURRENT RATING. T2 EQUIVALENT TRANSFORMER SHALL BE 28 VOLT SECONDARY, CENTER-TAPPED, WITH 1 AMP MINIMUM RATING.

15. CASE OF REGULATOR, LM323, AND HEAT SINK TABS OF REMAINING THREE REGULATORS ARE ALL AT DIFFERENT ELECTRICAL POTENTIALS. CAUTION SHOULD BE EXERCISED TO INSURE AGAINST DIRECT ELECTRICAL CONTACT BETWEEN THESE POINTS. THEY MUST NOT BE SHORTED TOGETHER, NOR TO THE HEATSINK OF THE LM323.

J3

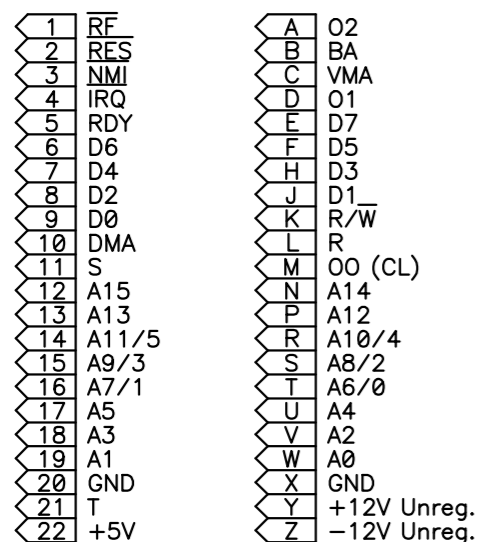

J2

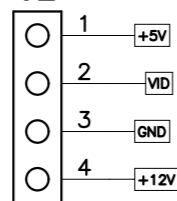

B4

